

Automatic Rigid Box Maker

RB185



About ZHENGRUN:

Wenzhou Zhengrun Machinery Co., Ltd. established in July 1997 at Pingyang Zhenglou Industrial Area. It has standard factory 22,000 square meters, 200 employees, and has become the best manufacturer for rigid box and case maker machinery equipped with most advanced CNC tooling machines in China. We have rights of self-managed import and export. Our company has been admitted to ISO9001 Quality Management System Certificate. The products have been admitted to Europe CE Certificate. Our products have been exported to Europe, America, South Africa, the Middle East and the Southeast Asia, more than seventy countries and regions. There are an agency networks all over the world.

For many years' development, our company is devoted itself to developing and researching new products and offering quality products to customers from home and abroad. It always abides by the enterprise idea '**Quality Builds Zhengrun Brand**'. We are spare no effort to manufacturing quality products and prospering the enterprise.



I . Instruction

Automatic Rigid Box Maker is a good equipment for making high-grade covered boxes for its fine design, reliable performances and advanced technologies. It employs PLC, photoelectric detector system, hydraulic pneumatic system, touch screen man-machine interface to automatically finish feeding and gluing paper, conveying cardboard, forming and gluing four angles of cardboard, positioning-sticking and forming box in one time. It is applicable to make high-grade boxes for cell phones, cosmetics, shoes, moon cakes, shirts, liquors, cigarettes, teas etc.

II . System Compositions

Product name: Automatic rigid box maker

Model: **RB185**



1. Main Accessories

- ◆ PLC System: Japanese YASKAWA PLC
- ◆ Transmission System: Taiwan Yintai
- ◆ Electric Components: French SCHNEIDER
- ◆ Hydraulic Components: Italy HYDR APP
- ◆ Pneumatic Components: Japanese SMC,
- ◆ Photoelectric Components: Japanese OMRON
- ◆ Converter: Japanese YASKAWA
- ◆ Servo motor: Japanese YASKAWA
- ◆ Touch screen: Japanese PRO-FACE

- ◆ Conveyer Belt: Swiss HABASIT
- ◆ Main Motor: Taiwan FUKUTA
- ◆ Bearing: Japanese NSK/IKO
- ◆ Gluing cylinder: chromed Stainless steel (New processes)

2. Basic Functions:

- (1) Automatic delivery unit for paper feeder.
- (2) Automatic circulation, mixing and gluing system for hot-melting gel. (Optional device: glue viscosity meter)
- (3) Hot-melting adhesives paper-gluing automatic conveying, slitter, and finish pasting the inner cardboard box's four angles in one process.
- (4) The vacuum suction fan under the conveyer belt can keep the glued paper from deviating.
- (5) The glued paper and cardboard inner box employ hydraulic pneumatic rectifying device to spot correctly. The spotting error is ± 0.5 mm.
- (6) The box-forming unit can automatically collect boxes and deliver them to the forming unit according to the boxes conveyed on the conveyer belt.
- (7) The box-forming unit can continually delivery boxes, wrap sides, fold ears and paper sides and form in one process.
- (8) The whole machine employs PLC, photoelectric detector system and touch screen man-machine interface to automatically form boxes in one process.
- (9) It can automatically diagnose the troubles and alarm accordingly.

3. Functions and Characteristics

The automatic rigid box maker is composed of Gluer (the paper-gluing unit), Former (four-angle sticking unit), Spotter (the positioning-sticking unit) and Wrapper (the box forming unit), which are controlled through a PLC in a linkage mode.

(1) Gluer (the paper gluing unit)

- ◆ New designed servo controlled paper feeder adopts post-sucking pre-pushing type to convey paper which efficiently avoids two pieces of papers entering into the machine.

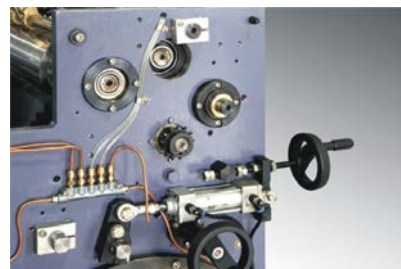
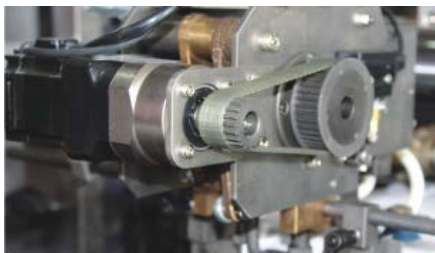



- ◆ The concentrated oil system fully ensures each parts lubricating and the steady running of machine.
- ◆ The gel tank is of consistent temperature, and can automatically mix, filter and glue in a circulation manner.
- ◆ The gel tank has a fast shift valve, through which the user can have the gluing cylinder cleaned quickly in 3 to 5 minutes.
- ◆ Chromatic-plated stainless steel cylinder, the latest technology, is applicable to different gels, featuring in durability.

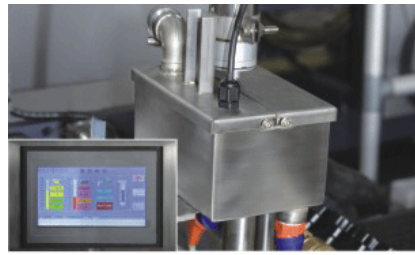

- ◆ Optional device: glue viscosity meter.

(2) Former (the four-angle sticking unit)

- ◆ The feeder automatically feeds the cardboards. The cardboards can be stacked in 1000mm high.
- ◆ The cardboard fast stacker and shifter

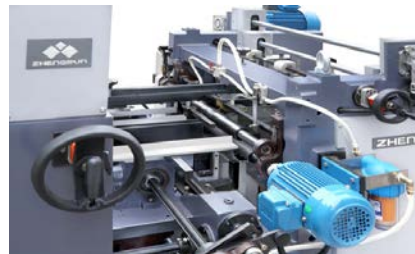

- ◆ The hot-melting glued tape auto conveyor, cutter and four-angle sticking
- ◆ The auto alarm for hot-melting glue tape absence
- ◆ Auto conveyor belt connected to quad stayer and the positioning-sticking unit.
- ◆ The cardboard feeder can automatically monitor the running according to the machines in linking mode.

(3) Spotter (the positioning-sticking unit)

- ◆ The vacuum suction fan under the conveyor belt can keep the glued paper from deviating.



- ◆ Imported higher precision photoelectric monitor
- ◆ The hydraulic pneumatic rectifier is of faster and more accurate response.

(4) Wrapper (the box forming unit)

- ◆ The gripper device can lift the box by the air cylinder which is efficiently avoiding the scratches of the paper.

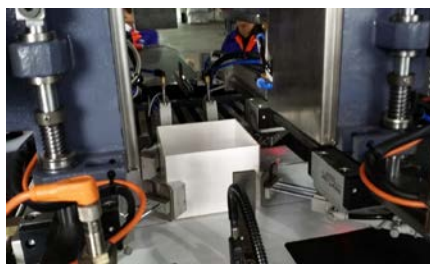

- ◆ Adopt new design of servo and pneumatic control structure to wrap the box, fast digital adjustment of sizes.



- ◆ Adopt air cylinder to folding paper ears, which can finish different box request.
- ◆ It can finish the box of single fold-in and multi-fold-in processes.

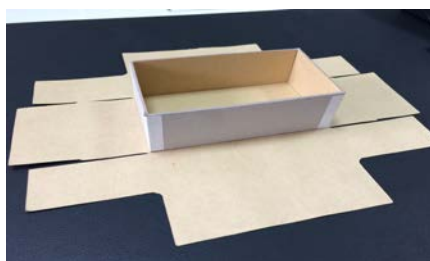
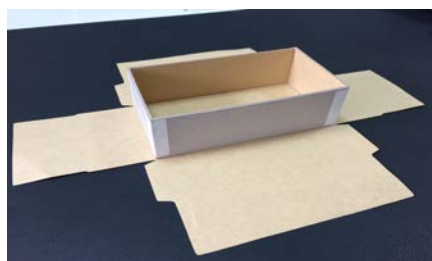

- ◆ Non mid mold design, efficiently avoid the trouble of mold cleaning, which made the fold-in size deeper(Max. 100mm)

◆ Safety operation and protector



III. Technical Parameter:

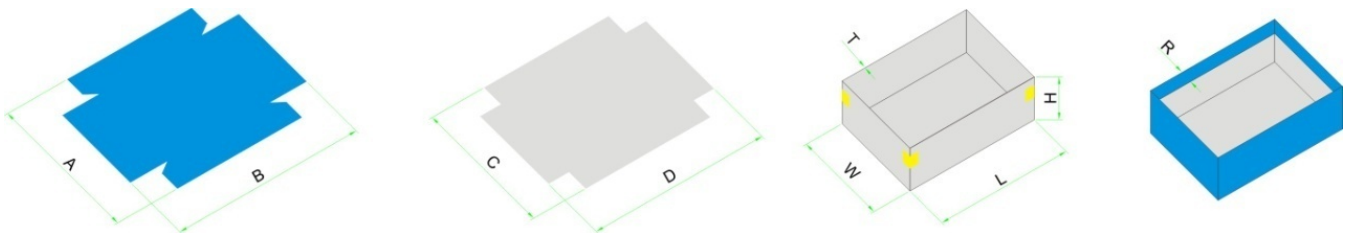

The corresponding relation between the specifications:

$$W+2H-4T \leq C(\text{Max})$$

$$L+2H-4T \leq D(\text{Max})$$

$$A(\text{Min}) \leq W+2H+2T+2R \leq A(\text{Max})$$

$$B(\text{Min}) \leq L+2H+2T+2R \leq B(\text{Max})$$

Production flow:

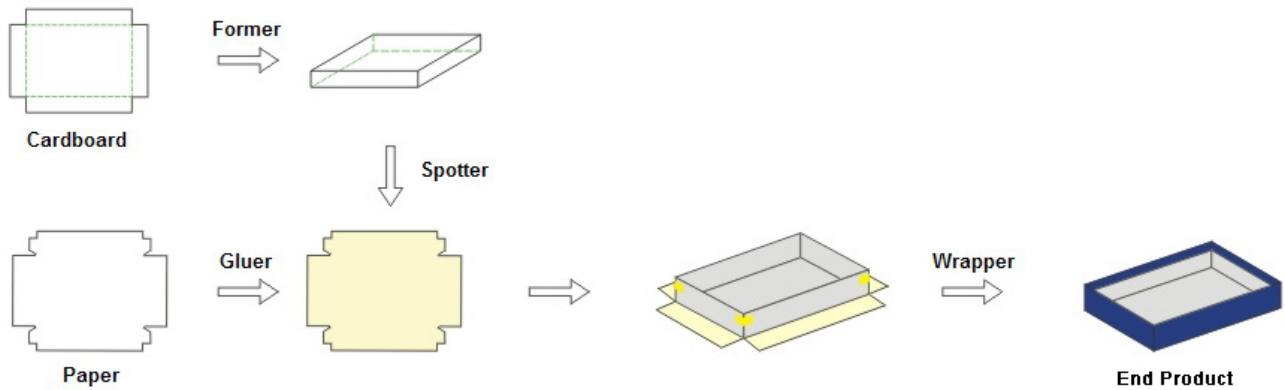

RB185 Automatic rigid box maker			
1	Paper size(AxB)	Amin	120mm
		Amax	610mm
		Bmin	250mm
		Bmax	850mm
2	Paper thickness		100-200g/m ²
3	Cardboard thickness(T)		0.8~3mm
4	Finished product(box)	Wmin	50mm



	size (W×L×H)	Wmax	400mm
		Lmin	100mm
		Lmax	600mm
		Hmin	12mm
		Hmax	185mm
5	Folded paper size (R)	Rmin	10mm
		Rmax	100mm
6	Precision	±0.50mm	
7	Production speed	≅ 25sheets/min	
8	Motor power	17.29kw/380v 3phase	
9	Heater power	6kw	
10	Air supply	50L/min 0.6Mpa	
11	Machine weight	6800kg	
12	Machine dimension	L7000×W4100×H 3600mm	

Note:

- ◆ The max and mini sizes of the boxes are subjected to those of the paper and the quality of the paper
- ◆ The speed of the machine depends on the sizes of the boxes
- ◆ Stacking Height for the cardboard: 1000mm (Max)
- ◆ Hot melting glue paper tape max. diameter: 350mm, inside diameter: 50mm
- ◆ Paper stacking height: 300mm (Max)
- ◆ Gel tank volume: 60L

Samples:

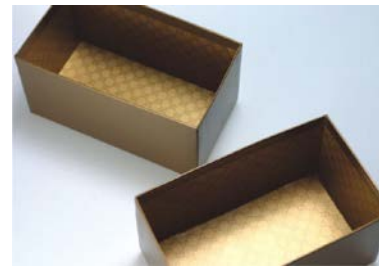

IV. Important Observations for purchasing

1. Requirements for Ground

The machine should be mounted on the flat and firm ground which can ensure it has enough capacity of load (about 500kg/m²). Around the machine should keep enough space for operation and maintenance.

2. Size

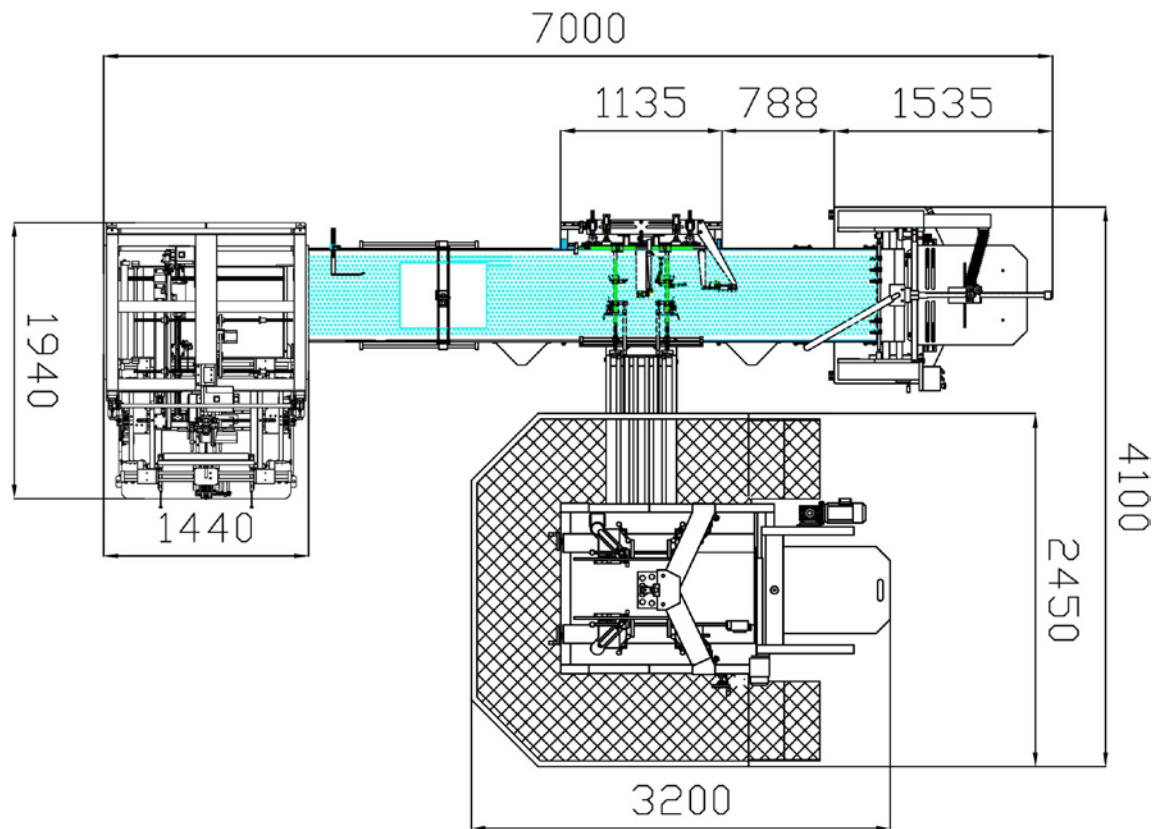

3. Ambient Conditions

- ◆ Temperature: the ambient temperature should be kept around 18-24°C(The air-conditioner should be equipped in summer.)
- ◆ Humidity: The humidity should be controlled around 50%-60%.
- ◆ Lighting: above 300LUX that can ensure the photoelectric components can work regularly.
- ◆ To be away from oil gas, chemicals, acidic, alkali, explosive and inflammable substances.
- ◆ To keep the machine from vibrating and shaking and being next to the electric apparatus with high-frequency electromagnetic field.
- ◆ To keep it from being directly exposed to the sun.
- ◆ To keep it from being blown directly by the fan.

4. Requirements for Materials

- ◆ Paper and cardboards should be kept flat all the time. The humidity of cardboards should be kept around 9%-13%
- ◆ The paper laminating should be electro-statically processed in double-side.

5. The color of the glued paper is similar to or same to that of the conveyor belt (black), and another color of glued tape should be stuck on the conveyor belt.
6. The power supply: 3 phase 380V/50Hz (sometimes, it can be 220V/50Hz、415V/Hz according to the actual conditions in different countries).
7. The air supply: 5-8 atmospheres (atmosphere pressure), 10L/min. The poor quality of air will mainly resulted in troubles for the machines. It will seriously reduce the reliability and life of the pneumatic system, which will result in lager loss or damage that may terribly exceed the costs and maintenance of such system. Therefore it must be technically allocated with a good quality air supply system and their elements. The followings are the air purifying methods only for reference:

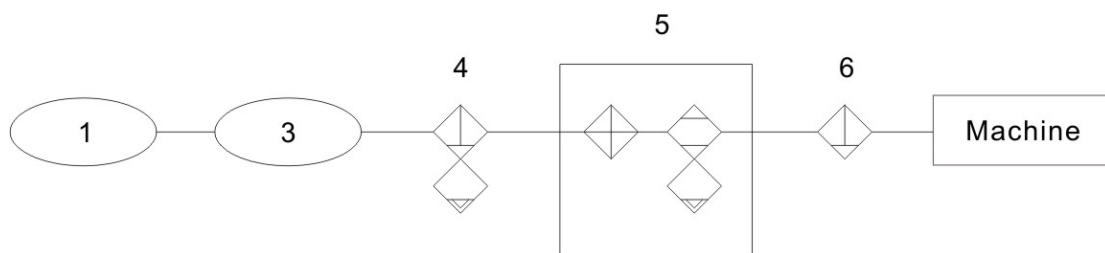

1	Air compressor		
3	Air tank	4	Major pipeline filter
5	Coolant style drier	6	Oil mist separator

- ◆ The air compressor is a non-standard component for this machine. This machine is not provided with an air compressor. It is bought by the customers independently.
- ◆ The function of the air tank:
 - a. To partly cool the air with higher temperature coming out from the air compressor through the air tank.
 - b. To stabilize the pressure that the actuator elements in the back uses for the pneumatic elements.
- ◆ The major pipeline filter is to remove the oil distain, water and dust, etc. in the compressed air in order to improve the work efficiency of the drier in the next process and to prolong the life of the precision filter and drier in the back.
- ◆ Coolant style drier is to filter and separate the water or moisture in the compressed air processed by the cooler, the oil-water separator, air tank and major pipe filter after the compressed air has been removed.



- ◆ The oil mist separator is to filter and separate the water or moisture in the compressed air processed by the drier.
8. Persons: for the sake of the safety of the operator and the machine, and fully taking advantage of the performance of the machine and reducing troubles and prolonging its life, 2-3 persons, skillful technicians capable of operating and maintaining machines should be assigned to operate the machine.
9. Auxiliary materials
- ◆ The hot melting glue tape specification: Width 22mm, Thickness 105 g/m², Outer diameter: 350mm(Max), Inner diameter 50mm, Length 300m/Circle, Melting point: 150-180°C
 - ◆ Glue: animal glue(jelly gel, Shili gel), specification: high speed fast dry style