

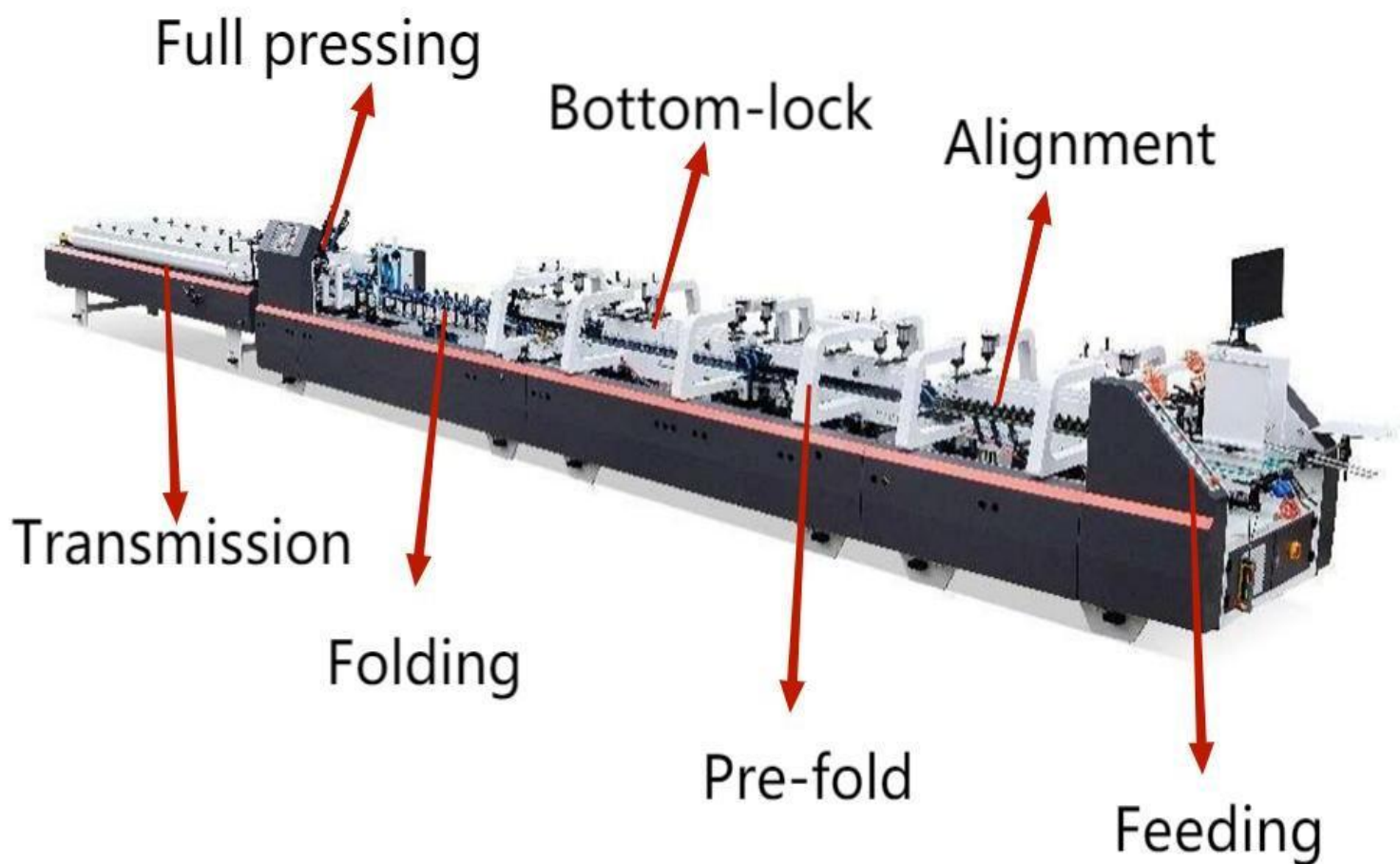

YZ- 980 PC

Intelligent Folder Gluer

It is widely used in food, medicine, cosmetics, stationery and other ordinary cartons, process and glue for all kinds of bottom-locked cartons. Pre-fold section is applied to auto packaging, fold 1 and fold 3 of all cartons can reach 180° and 135°, perfectly combining the requirements of auto packaging together.



Details Images

1

Feeding

5-6pcs Adjustable feeding belts to ensure easy adjustment, stable and smoothly feeding.
Continuously Variable Speeder to ensure feeding internal and stable transmission.
One-touch Pneumatic knife, easy for the adjustment of feeding belts.

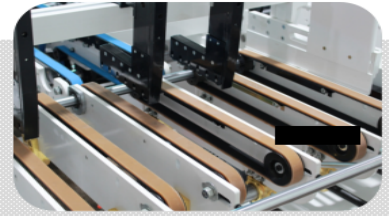

2

Alignment

Alignment section, which automatically corrects the box after it is ejected from the paper feed section



3

The Grinding part

More effective treatment of paper surface UV, the carton adhesive more stronger



4

Pre-fold

Double-board structure with a set of pre-folding knife.
Pre-fold angle is 180° and 135°, especially suitable for small but high cartons, more satisfactory while rapid prototyping

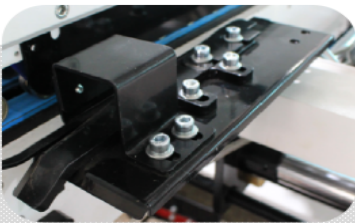

5

Bottom-lock

3-board tracking structure, upper gluer can make bottom-locked box automatic gluing and forming, can be used for the special-shaped cartons. The entire bottom-lock part is installed in a reversible bracket, substantially reduce the swap adjustment time of bottom-fold box and the other types of box.
Bottom-folding speed is 50-200 pcs per min, stable and reliable.



6

Folding

Lengthened folding to avoid the unevenness while the rapid forming of cartons and make it come to perfection.



7

Full pressing

2-board structure

Two modes for pressing belt speeding:

Auto: set distance between boxes, pressing belt speed is the same as the machine, belt removes while sensor detect it.

Manual: pressing belt conveys in a fixed speed and machine speed will not put any effect on it. With counting device to count the finished boxes to match with boxes regulating, easy to count and pack.



8

Transmission

Equipped with feeding paper inspection device.

Equipped with impacting device to press the paper after accounting and make it easy to pack paper.



Parameters

Model	AK-J800
Paper Material	Cardboard (200-800g) 、 E-flute/F-flute
Max. Liner speed	Max. 220 meter/minute
Feeding way	Automatically and continuously feeding
Way of folding	Fold 1 and fold 3 are 180°and 135° Fold 2 and fold 4 are 180° Bottom folded and glued
Glue Material	Water-base cold glue
Electric power	7KW 380V 50HZ 3P
Weight	2700KG
Over dimension	11500 x1300x 1400mm

Lock bottom carton type and folded box size :			
Model	SHH-800AK-J (folding belt 35mm)		
Type	Cardboard	瓦楞 Corrugated	
A	150-600mm	150-550mm	
B	200-750mm	200-750mm	
C	Min:30mm	Min:30mm	
D	Min:70mm	Min:70mm	
E	Min:30mm	Min:30mm	
F	Min:80mm	Min:80mm	
Common box type and size :			
Model	SHH-800AK-J (folding belt 35mm)		
Type	Cardboard	E/F Corrugated	
A	120-700mm	150-550mm	
B	120-780mm	200-750mm	
C	Min:10mm	Min:10mm	
D	Min:50mm	Min:100mm	
F	Min:50mm	Min:75mm	
Two-side gluing box type and size:			
Type	SHH-800AK-J		
A	100-450mm		
B	100-700mm		
C	70-600mm		
D	10-200mm		

Configuration

		
<p>Main Board 12MM hot and cold processed standard steel plate</p>	<p>Board for conveyor 8MM hot and cold processed standard steel plate</p>	<p>Main motor Taili Taiwan</p>
		
<p>Feed motor NANJIANG Made in china</p>	<p>Conveying motor NANJIANG Made in china</p>	<p>Converter EURA Made in china</p>
		
<p>Touchscreen MCGS Made in china</p>	<p>PLC MIKOM Made in china</p>	<p>Intermediate relay IDEC JAPAN</p>
		
<p>Circuit Breaker DELIXI Made in china</p>	<p>Button TENGEN Made in china</p>	<p>Travel Switch TENGEN Made in china</p>

		
<p>Photo electricity TENGLONG Made in china</p>	<p>Press Switch+ Remote controller PISO Made in china</p>	<p>Switch power supply Changxin Made in china</p>
		
<p>DC Switch power supply MEAN WELL Made in china</p>	<p>Main conveyor belt Ammeraal Beltech Netherlands</p>	<p>Bearing HRB Made in china</p>
		
<p>Transmission bearing HRB Made in china</p>	<p>Mound layer, roller Special section bar, hot processed 特</p>	<p>Chrome bar Through quenching-tempering</p>

Application





Optional hotmelt system

The tankless hot melt system is designed for melting and pumping of thermoplastic hot melt in granulate form. It gently melts on demand and therefore is applicable for both high and low glue consumption applications. Optional volume control monitors changes in adhesive consumption. Thanks to the fast heat-up time of 16 minutes to 160 °C the Concept Stream is quickly operational.



Optional Spraying System (water-base cold)

For irregular box, Need Extra Spraying System. convenient in the production various special box, gluing quickly and accurately sizing.
(Options: customized on user order)



Optional Plasma system

Through surface coating treatment, to strengthen the adherence and make cartons easier to be glued.



Optional Auto closed machine

The machine reduces labor intensity, saves manpower, improves the working efficiency of the folder gluer machine, and can make the performance of the folder gluer machine fully play.



pressnet@pressnet.com.au

0412 720060